

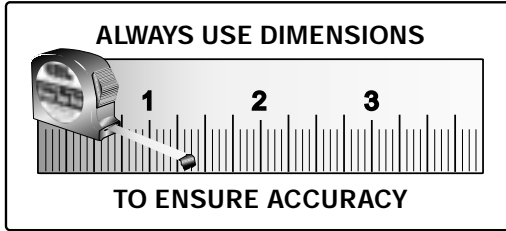

C.R. LAURENCE CO., INC.
PROFESSIONAL QUALITY

FRONT ELEVATION

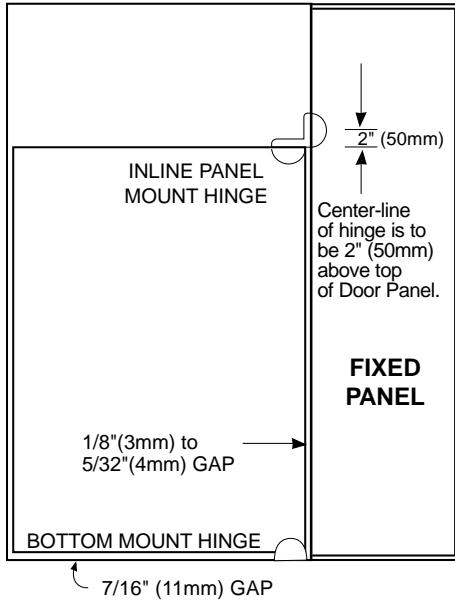

IMPORTANT:
Project measurements from the edge of the glass. 2" (50mm)

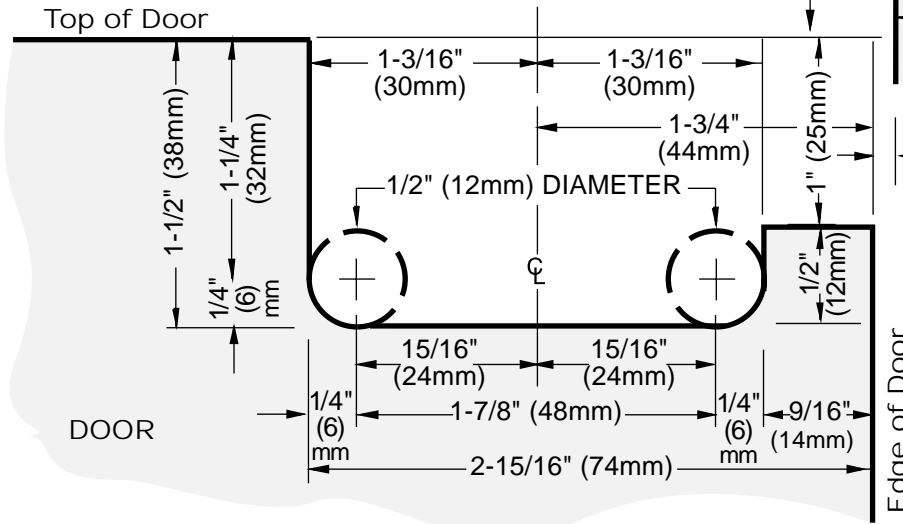
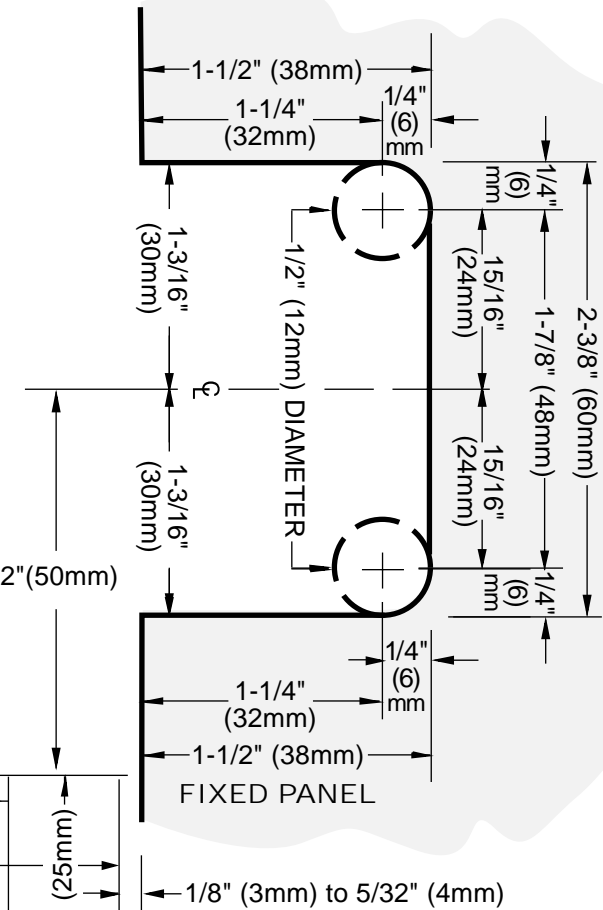

RONDO

Inline Panel Hinge
CAT No. RON004

Alternate Method (Even with Top of Door)